

Velvet™ Plug-in

Version 1.0



Copyright

© 2006 Digidesign, a division of Avid Technology, Inc. All rights reserved. This guide may not be duplicated in whole or in part without the express written consent of Digidesign.

Digidesign, Avid, Pro Tools, Pro Tools|HD, Pro Tools LE, Pro Tools M-Powered, Digidesign Digi 002, Digidesign Command|8, Digidesign Control|24, Digidesign D-Command, Digidesign D-Control, Digidesign ProControl, RTAS, and Velvet are either trademarks or registered trademarks of Avid Technology, Inc. in the US and other countries. All other trademarks contained herein are the property of their respective owners.

Product features, specifications, system requirements, and availability are subject to change without notice.

PN 9329-55885-00 REV A 9/06

contents

Chapter 1. Introduction	1
System Requirements	2
Register Your Plug-ins	2
Working with Plug-ins	2
Conventions Used in This Guide	3
About www.digidesign.com	3
Chapter 2. Installation	5
Installing the Velvet Plug-in	5
Authorizing Velvet	5
Removing Velvet	6
Chapter 3. Overview	7
Structural Overview	8
Chapter 4. Operating Velvet	11
Adjusting Parameters	11
Chapter 5. Velvet Parameters	13
Piano Front Panel	13
Setup Section	15
Preamp, EQ, and FX Section	19
MIDI Controller Mapping	23
Appendix A. Velvet Signal Flow	25
Appendix B. Insert Effects	27
Appendix C. Default MIDI Controller Assignments	33

chapter 1

Introduction

The new Velvet™ plug-in is an RTAS plug-in instrument for Pro Tools|HD®, Pro Tools LE™, and Pro Tools M-Powered™ systems brought to you by DigiDesign®. Velvet offers vintage electric piano sounds with unprecedented realism, control, and playability.

 *For more information on using plug-ins in Pro Tools, see the DigiRack Plug-ins Guide.*

Velvet Features

- ◆ Four legendary stage piano models: MK I, MK II, Suitcase, and A200. Velvet revives the legendary sound and feel of three Fender Rhodes* pianos and a Wurlitzer A200 piano.
 - ◆ Proprietary seamless dynamic modeling technology, based on select, mint-condition originals. Velvet accurately reproduces the sound of legendary electromagnetic pianos with vivid realism.
 - ◆ Mechanical keyboard noises can be added to the pickup signal, making it feel like the real thing rather than just triggering samples.
 - ◆ Overall timbre, as well dynamic response and velocity curve, can be adjusted individually to recreate the whole range of electric piano models from various decades.
- ◆ In addition to a built-in pre-amp with tube drive, and a 3-band EQ and compressor, the FX section not only features legendary analog effects, including Tape Echo, Analog Chorus/Flanger/Phaser, and Ringmodulator, but also Bit Crusher and Distortion.
 - ◆ More convenient than the original: While Velvet sounds and feels as great as a real electric piano, it lacks disadvantages of the original, such as price, maintenance efforts, limited portability, and no MIDI input.

** Velvet is not connected with, or approved or endorsed by, the owners of the Fender Rhodes and Wurlitzer trademarks. These names are solely used to identify the electric pianos emulated by this product.*

System Requirements

To use Digidesign RTAS plug-ins you need the following:

- ◆ An iLok USB Smart Key (an iLok.com account is also required for managing iLok licenses)
- ◆ A Digidesign-qualified Pro Tools|HD system, Pro Tools LE system, or Pro Tools M-Powered system
 - or –
- ◆ A Digidesign-qualified Pro Tools system and a third-party software application that supports the Digidesign RTAS plug-in standard

For complete system requirements visit the Digidesign website (www.digidesign.com).

Compatibility Information

Digidesign can only assure compatibility and provide support for hardware and software it has tested and approved.

For a list of Digidesign-qualified computers, operating systems, hard drives, and third-party devices, refer to the Digidesign website (www.digidesign.com).

Register Your Plug-ins

If you purchase a plug-in online from the Digi-Store (www.digidesign.com) using Internet Activation, you are automatically registered.

If you purchase a boxed version of a plug-in, check the enclosed Digidesign Registration Information Card for information about how to register online.

Registered users will receive periodic software update and upgrade notices.

Please refer to the Digidesign website (www.digidesign.com) or the Digidesign Registration Information Card for information on technical support.

Working with Plug-ins

Refer to the *DigiRack Plug-ins Guide* for information on working with plug-ins, including:

- Inserting plug-ins on tracks
- Using Clip indicators
- Navigating the Plug-in window
- Adjusting parameters
- Automating plug-ins
- Using the Librarian

 For information on using Instrument, Auxiliary Input, and MIDI tracks with instrument plug-ins, see the *Pro Tools Reference Guide*.

 For information on configuring Pro Tools for MIDI, see your *Getting Started Guide*.

Conventions Used in This Guide

All Digidesign guides use the following conventions to indicate menu choices and key commands:

Convention	Action
File > Save	Choose Save from the File menu
Control+N	Hold down the Control key and press the N key
Control-click	Hold down the Control key and click the mouse button
Right-click	Click with the right mouse button

The following symbols are used to highlight important information:



User Tips are helpful hints for getting the most from your Pro Tools system.



Important Notices include information that could affect your Pro Tools session data or the performance of your Pro Tools system.



Shortcuts show you useful keyboard or mouse shortcuts.



Cross References point to related sections in this guide and other Digidesign guides.

About www.digidesign.com

The Digidesign website (www.digidesign.com) is your best online source for information to help you get the most out of your Pro Tools system. The following are just a few of the services and features available.

Registration Register your purchase online. See the enclosed registration form for details.

Support Contact Digidesign Technical Support or Customer Service; download software updates and the latest online manuals; browse the Compatibility documents for system requirements; search the online Answerbase or join the worldwide Pro Tools community on the Digidesign User Conference.

Training and Education Study on your own using courses available online or find out how you can learn in a classroom setting at a certified Pro Tools training center.

Products and Developers Learn about Digidesign products; download demo software or learn about our Development Partners and their plugins, applications, and hardware.

News and Events Get the latest news from Digidesign or sign up for a Pro Tools demo.

To learn more about these and other resources available from Digidesign, visit the Digidesign website (www.digidesign.com).

chapter 2

Installation

Installing the Velvet Plug-in

The Velvet plug-in installer can be found on the Velvet Install Disc.

Installation

To install the Velvet plug-in:

- 1 Insert the Install Disc into your computer.
- 2 Double-click the Velvet Installer application.
- 3 Follow the on-screen instructions to complete the installation of plug-in and content.

 *During installation you will be asked where to place the plug-in content (waveform data). You need 700 MB of free memory on the selected hard drive to install Velvet.*

- 4 When installation is complete, click Finish (Windows) or Close (Macintosh).

The Velvet Installer installs the Velvet plug-in in the following location:

- Program Files/Common Files/Digidesign/DAE/Plug-Ins (Windows)
- or –
- /Library/Application Support/Digidesign/Plug-Ins (Macintosh).

Authorizing Velvet

Velvet is authorized using the iLok USB Smart Key (iLok), manufactured by PACE Anti-Piracy, Inc.

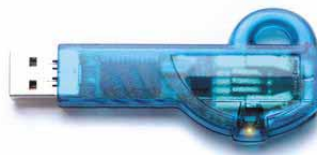

iLok USB Smart Key

The iLok is similar to a dongle, but unlike a dongle, it is designed to securely authorize multiple software applications from a variety of software developers.

This key can hold over 100 licenses for all of your iLok-enabled software. Once an iLok is authorized for a given piece of software, you can use the iLok to authorize that software on any computer.

A *The iLok USB Smart Key is not supplied with your plug-in or software option. You can use the one included with certain Pro Tools systems (such as Pro Tools|HD-series systems), or purchase one separately.*

You have to authorize online with the Activation Code included with your purchase (see “Authorizing Velvet Using an Activation Code” on page 6).

 See the *iLok Usage Guide* for details, or visit the *iLok website* (www.iLok.com).

Authorizing Velvet Using an Activation Code

To authorize Velvet using an Activation Code:

- 1 If you do not have an existing iLok.com account, visit www.iLok.com and sign up for an iLok.com account.
- 2 Transfer your Velvet license to your iLok.com account by doing the following:
 - Visit <http://secure.digidesign.com/activation>.
 - Input your Activation Code (listed on the Activation Card) and your iLok.com User ID. Your iLok.com User ID is the name you create for your iLok.com account.
- 3 Transfer the licenses from your iLok.com account to your iLok USB Smart Key by doing the following:
 - Insert the iLok into an available USB port on your computer.
 - Go to www.iLok.com and log in.
 - Follow the on-screen instructions for transferring your licenses to your iLok.

 For additional information about iLok technology and licenses, see the electronic PDF of the *iLok Usage Guide*.

- 4 Launch Pro Tools.
- 5 If you have any installed unauthorized plug-ins or software options, you will be prompted to authorize them. Follow the on-screen instructions to complete the authorization process.

Removing Velvet

If you need to remove the Velvet plug-in from your system, follow the instructions below for your computer platform.

Windows

To remove the Velvet plug-in:

- 1 From the Start menu, choose Settings > Control Panel and double-click Add or Remove Programs.
- 2 Select the Velvet plug-in from the list of installed applications and click the Change/Remove button.
- 3 Follow the on-screen instructions to remove the plug-in and content.
- 4 When removal is complete, click OK to close the window.

Mac OS X

To remove the Velvet plug-in:

- 1 Locate and open the Plug-Ins folder on your Startup drive (Library/Application Support/Digidesign/Plug-Ins).
- 2 Drag the Velvet plug-in to the Trash, or to the Plug-Ins (Unused) folder.
- 3 Drag the content file (Velvet data.big) from the folder to which you installed the Velvet plug-in content to the trash.
- 4 Empty the trash.

chapter 3

Overview

Velvet is an RTAS plug-in instrument that can be used to add the realistic sound of vintage electric pianos to any Pro Tools session.

Velvet provides four high-quality models of rare and legendary electric pianos. Velvet has been developed to deliver unprecedented realism in terms of sound quality and playability.

Using proprietary technology, Velvet provides all the nuanced details that influence the sound of a vintage electric piano.

A built-in pre-amp and custom equalizer, as well as a multi-effect section with sixteen effects make Velvet the perfect choice for reproducing all kinds of electric piano sounds of the past and present in your Pro Tools session.

Structural Overview



Piano Front panel

Preamp/EQ/FX section

Velvet Plug-in

Control Sections

The Velvet interface provides three Control sections. Each section provides parameters that correspond to a certain aspect of creating an electric piano sound in a recording situation.

Piano Front Panel Provides a Piano Model selector, Master Volume control, and Tremolo/Auto-pan controls. You can play Velvet by using MIDI input from a MIDI keyboard, from MIDI data in an Instrument or MIDI track in Pro Tools, or by clicking the 73 keys.

For more information about the Piano Front panel, see “Piano Front Panel” on page 13.

Setup Section Provides control over the basic sound and behavior of the selected electric piano model. You can manipulate and tune Velvet in the Source section—for example, mix in mechanical noises, or adjust the velocity sensitivity.

For more information, see “Setup Section” on page 15.

Preamp/FX Section Provides controls to adjust and shape the electric piano sound using a one-knob Compressor, Tube Drive, Equalizer, and a selection of stomp-box and studio effects.

For more information, see “Preamp, EQ, and FX Section” on page 19.

Velvet File Types

Setting

A Setting stores the complete state of the Velvet plug-in. A Setting can be loaded and saved by using the Plug-in Settings menu. Velvet's MIDI controller assignments are saved with the Pro Tools session, not with the setting.

 Refer to the *DigiRack Plug-ins Guide* for information on working with plug-in settings.

Electric Piano Models

Velvet provides four models of legendary electromagnetic pianos. While Velvet offers a large range of options for changing and adjusting the sound, choosing the right piano model is the most important step to achieve the desired sound and feel. Each of the four models has been accurately replicated from selected originals that have been adjusted and modified to perfection. Sound character, playing feel, and behavior is all based on the models.

Velvet is not connected with, or approved or endorsed by, the owners of the Fender Rhodes and Wurlitzer trademarks. These names are solely used to identify the electric pianos emulated by this product. References to artists and bands on the following pages are for informational purposes only and do not imply an endorsement or sponsorship of Velvet by such artists or bands.

 *The model names we used do not refer to the exact original pianos that were studied during the development of Velvet, but rather give you a hint to which kind of Rhodes or Wurlitzer sound is widely associated with the model.*

SC73 Is a model that creates the typical sound of the Rhodes Suitcase 73. The tines are set a soft character with lots of body. This model is ideal for ballads and blends nicely with other instruments. For an accurate suitcase sound, use the Stereo Tremolo on the Piano Front panel (Suitcase tremolo effect) and the “Large” setting of the Cab effects (Suitcase amp/speakers).

Musical styles:

- Jazz, Pop Ballads

Songs famous for featuring this instrument:

- Stevie Wonder—You are the sunshine of my life
- Billy Joel—Just the way you are
- Miles Davis—In a silent way, Bitches brew (Album)
- Bill Withers—Just the two of us

MK I Is a model of a very dynamic, vintage-style reproduction of a Fender Rhodes piano usually associated with the Mark I. The tines were moved close to the pickup for a full, harmonically rich timbre and a very hard sound at high velocities. Use this model for rhythmic chords and soloing—especially when you want the piano to stick out of the mix or compete against other instruments.

Musical styles:

- Jazz Fusion, Jazz Rock

Songs famous for featuring this instrument:

- Herbie Hancock—Head Hunters (Album)
- Jamiroquai—Space Cowboy
- George Duke—From dusk till dawn
- Chick Corea—Spain

MK II Is a model of the bright Rhodes piano sound that became famous in the 80s, usually with a condenser upgrade/modification for a very bright sound accentuating the metallic attack of the tines, further improved by tines set close to the pickups. This sound is very often referred to as “Dyno Rhodes.” Used by keyboardists David Foster (often combined with Grand Piano) and Robbie Buchanan.

Musical styles:

- Westcoast, Fusion, Pop

Songs famous for featuring this instrument:

- Al Jarreau—I will be here for you
- Whitney Houston—Saving all my love for you
- Chicago—Bad advice
- Donald Fagen—Green Flower Street

A200 Is a model of a Wurlitzer electric piano. The Wurlitzer was originally designed as a portable and cheap replacement for a real piano, but it’s aggressive, powerful sound character soon made it the only real competitor to the Rhodes pianos in pop and rock music. Many people refer to it as “the Supertramp” sound. The Wurlitzer can sound very nice and mellow in ballads, but it really excels in power accompaniment and rhythmic chords.

Musical styles:

- Blues, Pop, Rock.

Songs famous for featuring this instrument:

- Ray Charles—What’d I say
- Marvin Gaye—I heard it through the Grapevine
- Three Dog Night—Mama told me not to come
- Steely Dan—Pretzel Logic
- Pink Floyd—Money
- Supertramp—Dreamer
- Supertramp—Logical Song

chapter 4

Operating Velvet

Adjusting Parameters

You can adjust all controls by using the computer mouse to drag a control. Some controls are adjusted by selecting a value from a pop-up menu or by activating a button.

Parameter Ranges and Resolution

Most controls have a range of 0–100%, or display corresponding values such as Hz or dB. Some controls are *bipolar*, meaning they support negative values and usually have a range of –100% to +100%.

Using a Mouse

You can adjust controls by clicking and dragging the control's slider or knob, or by moving over it with the cursor and scrolling up or down with the scroll wheel. Adjust rotary controls by clicking and dragging horizontally or vertically. Parameter values increase as you drag upward or to the right, and decrease as you drag downward or to the left.



Dragging a knob

Activating Buttons

Some controls are enabled or disabled using buttons.

To enable a button:

- Click the button. Click again to disable it.



Enabling a button

Using Switches

Some values or modes are selected using switches.

To select a value using a switch:

- Right-click and drag the Switch to a new position.
– OR –
- Right-click a position on the Switch.



Using a switch

Keyboard Shortcuts

- ◆ For finer adjustments, hold down Control (Windows) or Command (Macintosh) while moving the control.
- ◆ To return a control to its default value, Alt-click (Windows) or Option-click (Macintosh) the control.

Displaying Values

Parameter values can be displayed without editing them.

To display the value of a control:

- Hover over the control with the cursor.

Scroll Wheel on Knobs, Faders, and Menus

If your mouse has a scroll wheel, you can use it to adjust Velvet parameters.

To change a value with a scroll wheel:

- 1 Move the cursor over a rotary knob or fader.
- 2 Scroll the wheel up to increase values. Scroll the wheel down to decrease values.

chapter 5

Velvet Parameters

Piano Front Panel

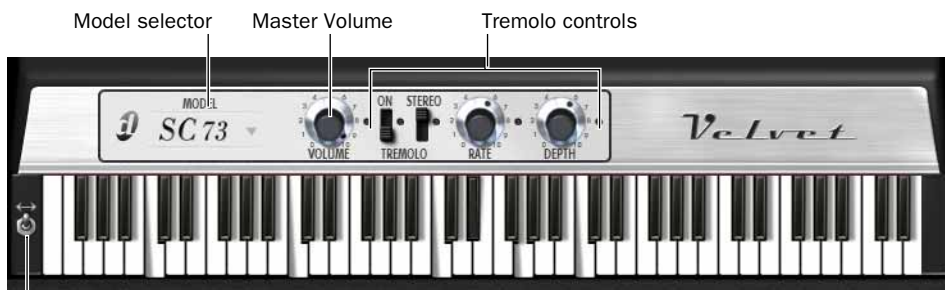

Keyboard Extension switch

Piano Front panel

The Piano Front panel provides the Piano Model selector, a Master Volume control, Tremolo/Autopan controls, and a Keyboard Extension switch. The 73 keys in the Keyboard section correspond to the keys of a MIDI keyboard and their MIDI notes starting from E0 on the left to E6 on the right. You can play Velvet by clicking keys, using MIDI input from a MIDI keyboard, or from MIDI data in an Instrument or MIDI track in Pro Tools.

Model Selector

Use the Model selector to load one of the four vintage electric piano models.

To load an electric piano model:

- Click the Model selector and select a piano model from the pop-up menu.

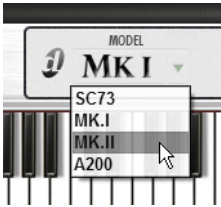

- ⚠ *Loading a piano model may take several seconds. During the loading process Velvet and Pro Tools remain unresponsive.*

Volume

The Volume control on the Piano Front panel is Velvet's main output to the Pro Tools track on which Velvet is inserted.

Tremolo

Tremolo is a typical vintage effect which was built into some electric pianos. Tremolo is a rhythmic variation in amplitude. Enabling its stereo mode applies a periodic variation of position in the stereo field. Velvet provides Tremolo effects for all models by reproducing the circuits of the Fender Rhodes Suitcase, and the Wurlitzer A200.

On/Off Switch Enables the Tremolo effect.

Mono/Stereo Switch Enables Mono or Stereo Tremolo mode.

Rate Adjusts the speed of the Tremolo effect.

Depth Adjusts the amount of Tremolo applied to the sound.

To position the Tremolo before the FX section in the signal chain:

- Right-click the Tremolo On/Off switch and choose Tremolo Before FX from the pop-up menu.



Tremolo before FX

Keyboard Extension Switch

The electric pianos in Velvet have the same key range as the original models (A0–C6 for the A200, E0–E6 for the others) to guarantee authenticity. Use the Key Extension switch to allow notes outside this range to be played.

To extend the model's keyboard range:

- Set the switch to the Up position.

Setup Section



Velvet Setup section

The Setup section provides controls for adjusting Velvet's basic setup and playing behavior—including adjustment of the Pickup level, mechanical noises, and Key release. You can also set the amount of waveform data loaded into RAM and Velvet's dynamic response.

Pickup Level

The Pickup Level control adjusts the volume of the line signal captured by the instruments pickups. Usually a vintage electric piano is recorded by connecting the instrument's line out directly to an amp or mixer. The Pickup level control adjusts the amount of this signal. Turn the Pickup Level control to the right to increase the line signal's volume.

Mechanics

The Mechanics controls adjust the type and amount of mechanical noises that occur when playing an electric piano—the sound of keys being pressed, as heard by the player. These sounds are not captured by the Pickups. Velvet is the first virtual electric piano that lets you add original mechanical noise to the sound for increased realism. There are three Mechanics modes.

Off Disables mechanical noises.

On Enables mechanical noises. Move the Mechanics knob to the right to increase the amount of mechanical noises.

Open Enables mechanical noise, modelling the sound of an electric piano with the lid removed. Move the Mechanics knob to the right to increase the amount of mechanical noise.

To make the Mechanics signal bypass the FX section:

- Right-click the Mechanics switch and select FX Bypass to send the Mechanics signal directly to Velvet's output, bypassing the FX section. In this mode only the Pickup signal passes through the FX section.

 Set the Mechanics control to On, and turn the Pickup Level control all the way down to hear the sound of a switched-off vintage electric piano.

Key Off

The Key Off controls adjust the type and volume of noise that occurs when releasing keys. The Key Off selector provides three modes.

Off Disables key release noise.

On Enables key release noise. Use the Key Off knob to adjust the level of key release noise.

Stacc (Staccato) Enables key release noise with a special behavior when short notes are played. Playing staccato notes on a real electric piano keeps the dampers from cutting off the note as fast as normal, resulting in a different release sound.

Key Off Level Adjusts the amount of key release noise.

 *The Key Off level also depends on the settings of Pickup and Mechanics controls.*

Pedal Noise

Velvet lets you add the noise of the sustain pedal captured by the Pickups and the mechanical noise of the pedal action audible for the player sitting at the piano.

To enable pedal noise:

- Right click the Key Off control and select Pedal Noise from the pop-up menu.



 *The volume of pedal noise is adjusted by the Pickup Level knob (amount of pedal noise captured by the pickups), and the Mechanics Level knob (amount of pedal noise heard by the player).*

Condition

The Condition control artificially ages the selected electric piano model. Turning the control to the right, introduces note-to-note deviations in tuning and dynamic response, simulating an old electric piano in need of service.

Mem (Memory Selector)

Use this control to adjust the amount of waveform data Velvet loads into your computer's RAM.

Eco Is the smallest possible load size. Eco uses fewer system resources, but also limits the range of expression available.

Mid Provides a good balance between system load and range of expression.

XXL Is the default load size. XXL, the largest possible load size, provides the maximum range of expression available, but also places the greatest demands on system resources.

Fine Tune

The Fine Tune control adjusts the tuning of Velvet. The maximum tuning deviation is 2 semitones up or down. Move the control to the right to raise and to the left lower the tuning.

 *Assign the Fine Tune control to your MIDI keyboard's Pitchbend wheel for pitch bend effects.*

Velo Curve (Velocity Curve)

Use the Velo Curve sliders to adjust Velvet's velocity sensitivity. The four sliders from the left to the right represent Velvet's velocity response from low to high.

For a wide dynamic range:

Set the Velocity Sliders as follows.



For no response to velocity:

Set the Velocity Sliders as follows.



For a normal response (default):

Set the Velocity Sliders as follows.



Velo Response (Velocity Response)

The Velocity Response controls adjust the range of volume and timbre available when playing at different velocities.

Volume Adjusts the range of volume available. Move the control to the left to reduce the variation in volume when playing from low to high velocities. Move the control to the right to increase the range.

Timbre Adjusts the range of timbre available. Move the control to the left to reduce the variation in timbre when playing from low to high velocities. Move the control to the right to increase the range.



MIDI keyboards can have different velocity response behavior. Use these parameters to adjust Velvet to the maximum velocity output of your MIDI keyboard.

Timbre

The Timbre control changes the overall sound of the selected electric piano model. Turn the control to the left for a soft, mellow sound, turn it to the right for a hard, bright sound. Used in combination with the Velocity Response controls, you can achieve any range of timbral response.

Preamp, EQ, and FX Section



Preamp, EQ, and FX section

Preamp Section Controls

In the Preamp section there are controls to adjust Velvet's sound using a compressor, tube overdrive, and a three-band equalizer with a parametric mid band. Velvet's signal passes through the Preamp section into the FX section.

Comp (Compressor)

The Compressor control adjusts Velvet's dynamics using a soft-knee compressor. Turn the Compressor control to the left to accentuate the attacks, and to the right to boost the signal's sustain phase.

Tube Drive

The Tube Drive control adds harmonics and compression to the signal, emulating the behavior of a tube preamp responding dynamically to the input level. Move the control to the right to increase the Tube Drive amount.

Equalizer Section Controls

The three-band Equalizer provides a low band, a high band, and a parametric mid band for adjusting Velvet's tone.

To enable/disable the Equalizer:

- Click the Equalizer button. The button is lit when enabled.



Equalizer button

Bass

The Bass control adjusts the amount of low frequencies using a vintage shelf equalizer curve. Turn the control to the left to attenuate, and to the right to boost low frequencies.

Parametric Mid Band

Freq Adjusts the center frequency of the mid band.

Mid Adjusts the level of frequencies around the center frequency. Turn the control to the left to attenuate, or to the right to boost the selected frequencies.

Q Value Adjusts the range of frequencies to be boosted or attenuated. Turn the control to the left for a wide bell shape. Turn it to the right for a narrow peak or notch.

Treble

The Treble control adjusts the amount of high frequencies using a vintage shelf equalizer curve. Turn the control to the left to attenuate, and to the right to boost high frequencies.

EQ Level

The EQ Level control rebalances the volume of Velvet's signal to compensate for level changes caused by the Equalizer. Turn the EQ Level control to the left to attenuate, and to the right to boost the signal before it is sent to the FX section.

FX (Effects) Section



FX section

In the FX section, Velvet provides five categories of classic vintage effects. You can select one effect from each category at a time. Taking a look at Velvet's signal flow, the FX section is placed after Setup and Preamp/Equalizer section, passing the signal to the Master Output Volume on the Piano Front panel.

FX Types

There are five Effect inserts corresponding to five effect categories each with up to four effects. Each Effect insert provides an Effect selector and a number of Parameter controls. The Parameter controls in one category always serve similar functions no matter which effect is selected.

Dist (Distortion)

- Fuzz
- Overdrive
- Crush

Wah

- LFO (Low Frequency Oscillator controlled)
- Env (Envelope)
- Env LP (Envelope Lowpass)

Mod (Modulation)

- Chorus
- Flanger
- Phaser 1
- Phaser 2

Cab (Cabinet)

- Small
- Large
- Amp

Del (Delay)

- Mono
- Stereo
- Tape

 See Appendix B, "Insert Effects" for detailed information about the effects, their parameters and descriptions

Using the FX section

To display an Effect insert and its controls:

- Click the Insert selector. If the Effect insert is already selected, clicking the Insert selector enables or disables the insert.



Selecting an Insert

To select an Effect:

- Click and drag the Mode selector.



Selecting an Effect

To enable/disable an Insert

- Click the Insert button. The Insert button is lit when enabled.



Enabling an Insert

To globally enable/disable the FX section:

- Click the FX button. The FX button is lit when the FX section is enabled.



Bypassing the FX section

To position the Wah before the Fuzz effect in the signal chain:

- Right-click the Wah Mode selector and choose Wah Before Fuzz from the pop-up menu.



Wah before Fuzz

To position the Tremolo before the FX section in the signal chain:

- Right-click the Tremolo On/Off switch and choose Tremolo Before FX from the pop-up menu.



Tremolo before FX

MIDI Controller Mapping

Velvet lets you assign standard MIDI controllers to virtually any parameter so that you can control Velvet from a MIDI controller in real-time.

To assign a MIDI controller to a parameter:

- 1 Right-click (Windows or Mac) or Control-click (Mac) a control.
- 2 Do one of the following:
 - Select the desired MIDI controller from the Assign pop-up menu.
 - or –
 - Choose Learn, and move the desired control on your MIDI controller. The parameter is automatically assigned to that control.



Assigning a MIDI controller

To un-assign a MIDI controller:

- 1 Right-click (Windows or Mac) or Control-click (Mac) a rotary control or fader.
- 2 From the pop-up menu, choose Forget.

 See Appendix C, “Default MIDI Controller Assignments” for detailed information about preset MIDI controllers.

appendix a

Velvet Signal Flow

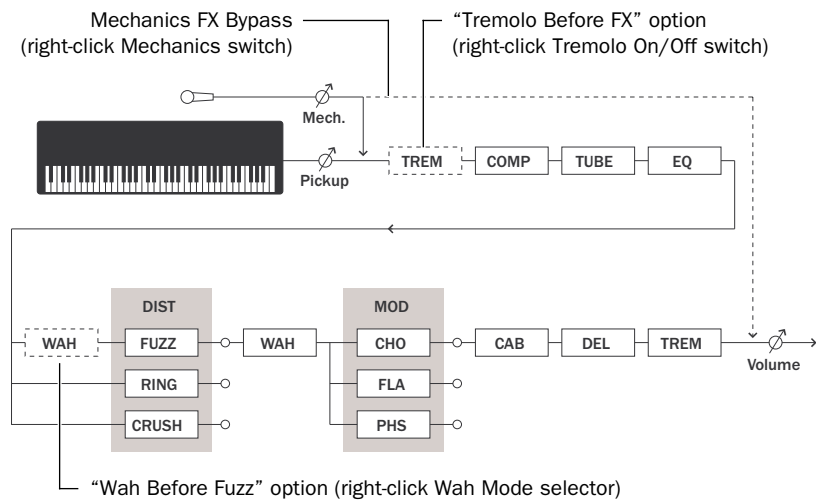

appendix b

Insert Effects

Category	Effect	Effect Description	Controls	Control Description
Dist	Fuzz	Transistor distortion, adding odd harmonics	Drive	Drive amount
			Freq	Tone
			Mix	Effect mix
	Ring	Ring modulator with envelope-controlled frequency	Freq	Carrier frequency
			Depth	Envelope modulation of modulator frequency (center = none)
			Mix	Effect mix
	Crush	Bitcrusher, reducing bit depth and sample rate	Freq	Sample rate
			Depth	Reduce bit depth
			Mix	Effect mix

Category	Effect	Effect Description	Controls	Control Description
Wah	LFO	LFO controlled periodic modulation	Pedal	Wah pedal position
			Rate	Modulation rate
			Depth	Modulation depth (center = none)
			Mode	Switches between two Wah types, US (American) and Brit (British)
	Env	Envelope-modulated wah	Freq	Wah pedal position
			Rate	Envelope tracking speed
			Depth	Envelope modulation depth
			Mode	Switches between two Wah types, US (American) and Brit (British)
	Env LP	Envelope modulated lowpass filter	Freq	Wah pedal position
			Rate	Envelope tracking speed
			Depth	Envelope modulation depth
			Mode	Switches between two Filter types, US (American) and Brit (British)

Category	Effect	Effect Description	Controls	Control Description		
Mod	Chorus	Stereo pitch modulation effect, softening sounds				
			Rate	Modulation rate		
			Depth	Modulation depth		
			Feedback	Feedback amount		
			Mix	Effect mix		
			Flanger	Sweeping phase-cancelling effect	Rate	Modulation rate
					Depth	Modulation depth
					Feedback	Feedback amount
					Mix	Effect mix
			Phaser 1	Gentle phase shifting effect	Rate	Modulation rate
					Stereo/Mono	Activate to set the modulation waveform 180° out of phase on the left and right channels, to add stereo movement
					Depth	Modulation depth
	Feedback	Feedback amount				
	Mix	Effect mix				
	Phaser 2	Stronger phase shifting effect			Rate	Modulation rate
			Stereo/Mono	Activate Stereo to set the modulation waveform 180° out of phase on the left and right channels, to add stereo movement		
			Depth	Modulation depth		
			Feedback	Feedback amount		
			Mix	Effect mix		

Category	Effect	Effect Description	Controls	Control Description
Cab		Amplifier emulations		
	Small	Emulation of a small electric piano built-in speaker	Bass	Low frequency tone control
			Mid	Midrange tone control
			Treble	High frequency tone control
			Amb	Adds natural room ambience
	Large	Emulation of large electric piano built-in speakers	Bass	Low frequency tone control
			Mid	Midrange tone control
			Treble	High frequency tone control
			Amb	Adds natural room ambience
	Amp	Emulation of an open-backed guitar amp	Bass	Low frequency tone control
			Mid	Midrange tone control
			Treble	High frequency tone control
			Amb	Adds natural room ambience

Category	Effect	Effect Description	Controls	Control Description
Delay	Mono	Simple mono echoes		
			Time	Delay time (in beats or milliseconds)
			Feedback	Number of repeats
			Tone	Progressively damps the high frequencies in each repeat
			Mix	Effect mix
	Stereo	Alternating left/right echoes	Sync	Synchronizes the delay repeats to the Session tempo
			Time	Delay time (in beats or milliseconds)
			Feedback	Number of repeats
			Tone	Progressively damps the high frequencies in each repeat
			Mix	Effect mix
	Tape	Emulation of an analog tape echo machine	Sync	Synchronizes the delay repeats to the Session tempo
			Time	Delay time (in beats or milliseconds)
			Feedback	Number of repeats, leading to self-oscillation at high settings
			Tone	Progressively damps the high frequencies in each repeat
			Mix	Input level to tape
			Sync	Synchronizes the delay repeats to the Session tempo

appendix c

Default MIDI Controller Assignments

Parameter	Controller	MIDI Standard
Tremolo Depth	1	Mod Wheel
Condition	2	Breath Control
Pickup Level	4	Foot Control
Fine Tune	5	Glide Time
Volume	7	Volume
Wah Pedal	11	Expression Pedal
Compression	12	Effect Control 1
Tube Drive	13	Effect Control 2
Delay Time	16	General Purpose 1
Delay Feedback	17	General Purpose 2
Delay Tone	18	General Purpose 3
Delay Mix	19	General Purpose 4
Mechanics Mode	20	
Mechanics Level	21	
EQ On/Off	25	
EQ Bass	26	
EQ Mid Frequency	27	
EQ Mid Gain	28	
EQ Mid Q	29	
EQ Treble	30	

Parameter	Controller	MIDI Standard
EQ Level	31	
Ring Frequency	46	
Ring Depth	47	
Ring Mix	52	
Crush Frequency	53	
Crush Depth	54	
Crush Mix	55	
Flanger Rate	56	
Flanger Depth	57	
Flanger Feedback	58	
Flanger Mix	59	
Phaser Rate	60	
Phaser Depth	61	
Phaser Feedback	62	
Phaser Stereo	63	
Velocity To Level	70	Sound Variation
Velocity To Timbre	71	Resonance
Key Off Level	72	Release Time
Key Off Mode	73	Attack Time
Tremolo On/Off	74	Cutoff
Tremolo Mode	75	Decay Time
Tremolo Rate	76	Vibrato Rate
Distortion On/Off	79	
Distortion Mode	80	
Fuzz Drive	81	
Fuzz Tone	82	
Fuzz Mix	83	

Parameter	Controller	MIDI Standard
Wah On/Off	85	
Wah Mode	86	
Wah Rate	87	
Wah Depth	88	
Wah Model	89	
Cab Ambience	91	Effect 1 Level (Reverb)
Chorus Mix	93	Effect 3 Level (Chorus)
Phaser Mix	95	Effect 5 Level (Phaser)
Mod On/Off	102	
Mod Mode	103	
Chorus Rate	104	
Chorus Depth	105	
Chorus Feedback	106	
Cab On/Off	107	
Cab Mode	108	
Cab Bass	109	
Cab Mid	110	
Cab Treble	111	
Delay On/Off	112	
Delay Mode	113	
Delay Sync	114	
Velocity Min	115	
Velocity Low Mid	116	
Velocity High Mid	117	
Velocity Max	118	
FX Global On/Off	119	
Timbre	Pitchbend	



www.digidesign.com

DIGIDESIGN

2001 Junipero Serra Boulevard
Daly City, CA 94014-3886 USA
Tel: 650.731.6300
Fax: 650.731.6399

TECHNICAL SUPPORT (USA)

Tel: 650.731.6100
Fax: 650.731.6384

PRODUCT INFORMATION (USA)

Tel: 800.333.2137

INTERNATIONAL OFFICES

Visit the Digidesign website
for contact information